



**ACT AON120D
Fiber Mini
Node**

**Quick Reference
Guide**

Revision B

ACT AON120D Fiber Mini Node

Quick Reference Guide

ACT Document Number: ACT AON120D QRG

Quick Reference Guide Revision C

Copyright © 2019 Ascent Communication Technology Limited.

All rights reserved. Reproduction in any manner whatsoever without the express written permission of Ascent Communication Technology is strictly forbidden.

This document is produced to assist professional and properly trained personnel with installation and maintenance issues for the product. The capabilities, system requirements and/or compatibility with third-party products described herein are subject to change without notice.

For more information, contact ACT: support@ascentcomtec.com



Revision History

Revision	Date	Reason for Change
A	04/26/2019	Initial release
B	05/15/2019	Minor updates
C	02/05/2020	Updating specifications table

Table of Contents

1 Introduction	5
1.1 Overview	5
1.2 Features.....	6
1.3 Specifications	7
1.4 System Connection	8
1.5 Models and Options.....	8
1.6 Block Diagram	9
2 Configuration and Installation.....	9
2.1 Equipment Inventory	9
2.2 Power and Cooling Requirements.....	9
2.3 Setting up the AON120D.....	9
3 Distortion Performance.....	11
4 Three-Wavelengths WDM Module	12
4.1 Features.....	12
4.2 Applications.....	12
4.3 WDM Specifications	12
4.4 PD Pin Assignment	13
4.5 Mechanical Dimensions	13
5 Troubleshooting	13

Precautions



Exposure to class 1M laser radiation is possible. Access should be restricted to trained personnel only. Do not view exposed fiber or connector ends when handling optical equipment.



- Ensure adequate cooling and ventilation as specified.
- The installation and operation manual should be read and understood before units are put into use.
- **Always replace protective caps on optical connectors when not in use.**
- The typical connectors fitted are SC/APC 8°. **Note:** 8° angle polished connectors must be used.

Cleaning

Use only a damp cloth for cleaning the front panel. Use a soft dry cloth to clean the top of the unit.

Do not use spray cleaner of any kind.

Overloading

Overloading wall outlets and extension cords can result in a risk of fire or electric shock.

Use approved electrical cords.

Damage requiring service

Unplug unit and refer servicing only to Ascent Communication Technology qualified service personnel.

Servicing

Do not attempt to service this unit yourself. Refer all servicing only to Ascent Communication Technology qualified service personnel.

General Reminders and Warnings

Review these reminders and warnings before you inspect and clean your fiber-optic connections.

Reminders



- **Always turn off any laser sources before you inspect fiber connectors, optical components, or bulkheads.**
- Always make sure that the cable is disconnected at both ends and that the card or pluggable receiver is removed from the chassis.
- **Always wear the appropriate safety glasses when required in your area. Be sure that any laser safety glasses meet federal and state regulations and are matched to the lasers used within your environment.**
- Always inspect the connectors or adapters before you clean.
- Always inspect and clean the connectors before you make a connection.
- Always use the connector housing to plug or unplug a fiber.
- **Always keep a protective cap on unplugged fiber connectors.**
- Always store unused protective caps in a resealable container in order to

prevent the possibility of the transfer of dust to the fiber. Locate the containers near the connectors for easy access.

- Always discard used tissues and swabs properly.

Warnings



- Never use alcohol or wet cleaning without a way to ensure that it does not leave residue on the endface. It can cause damage to the equipment.
- **Never look into a fiber while the system lasers are on.**
- Never clean bulkheads or receptacle devices without a way to inspect them.
- Never touch products without being properly grounded.
- **Never use unfiltered handheld magnifiers or focusing optics to inspect fiber connectors.**
- **Never connect a fiber to a fiberscope while the system lasers are on.**
- Never touch the end face of the fiber connectors.
- Never twist or pull forcefully on the fiber cable.
- Never reuse any tissue, swab, or cleaning cassette reel.
- Never touch the clean area of a tissue, swab, or cleaning fabric.
- Never touch any portion of a tissue or swab where alcohol was applied.
- Never touch the dispensing tip of an alcohol bottle.
- Never use alcohol around an open flame or spark; alcohol is very flammable.

1 Introduction

1.1 Overview

AON120D Series FTTH mini node supports Video Overlay application over FTTH optical fiber access network. It operates on 42 MHz to 1006 MHz RF bandwidth, with high output power up to 80 dB μ V (AGC). AON120D has low power consumption and optional built-in WDM to support PON signal pass-through. It is part of ACT's Deep Fiber and FTTH solution, which helps operators provide superior video services in a FTTH PON network architecture.

The AON120D Mini Node adopts high sensitivity optical receiver and specially designed low noise matching circuit. The mini node provides high output and is installed at the subscriber premises, suitable for advanced FTTx, high density MDU, SMB, or hospitality market applications. The AON120D mini node is designed with built in WDM optical passive, which will pass the 1310/1490nm data wavelength to the ONU/ONT CPE device.

With the compact housing, modular design, AON120D mini node provides the flexible configuration for MSOs to deliver advanced video services to their customer. This fiber deep product series improve overall network performance, and offer sufficient bandwidth for new application demand.

1.2 Features

- 1002 MHz RF Spectrum for superior video services
- Small form factor and low power consumption
- 1550 nm CATV wavelength
- 1310/1490 nm PON wavelength
- 1270/1577 XGSPON wavelength
- Wide optical receiving range: -18 dBm to +2 dBm
- Optical AGC to keep constant output level in different optical input power
- RF output level: 75 dB μ V \pm 1 dB μ V in AGC range
- LED indicator for optical power and power supply
- Powered directly using the power adaptor
- Compact enclosure fits easily in CPE, ONU housing or network termination boxes
- Special heat dissipation design

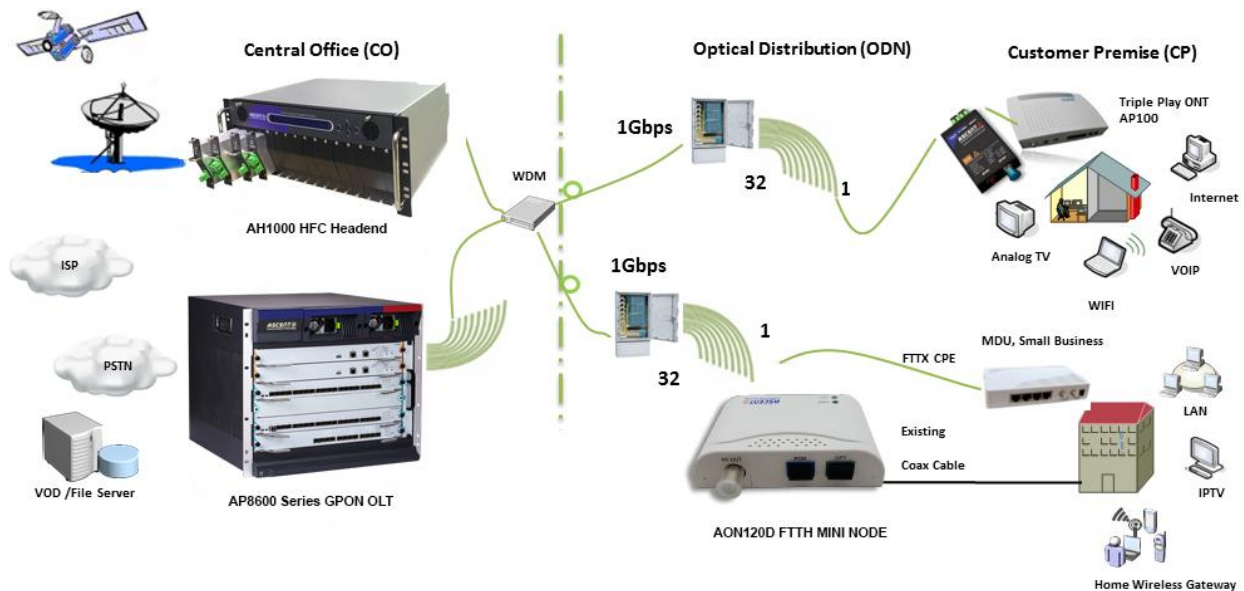

1.3 Specifications

AON120D FTTH Deep Fibre Mini Node

Optical Parameters

Whole Work Wavelength	1260 nm to 1620 nm	
CATV Work Wavelength	1540 nm to 1560 nm	
Reflection Band	1270 nm to 1530 nm and 1570 nm to 1620 nm	Available for GPON 1310/1490 and XGSPON 1270/1577
Insertion Loss (COM to Reflection Port)	≤1.0 dB	
Channel Isolation @ 1550 nm	≥30 dB	
Channel Isolation @Reflection Band	≥15 dB	
Receiving Power	+0 dBm to -9 dBm 0 dBm to -12 dBm	Analog TV (CNR > 43dB) Digital TV (MER > 31dB)
Optical Return Loss	≥50 dB	
Optical Fiber Connector	SC/APC SC/APC	COM port Reflection port

RF Parameters

Work Bandwidth	47 MHz to 1218 MHz	
Flatness	≤±1.25 dB	
AGC Range	-2 dBm to -12 dBm	
Output Level	75 dBμV ± 1 dBμV 75 dBμV ± 1 dBμV	Analog TV (Pin = -10dBm) Digital TV (Pin = -12dBm)
Return Loss	≥14 dB	47 MHz to 1002 MHz
Output Impedance	75 Ω	
Output Port Number	1	
RF Tie-in RF	F-Female	
MER	≥31 dB ≥29 dB	Pin = -12 dBm Pin = -15 dBm
BER	<1.0E-9	Pin: 0 dBm to -15 dBm

General Characteristics

Power Supply	+12 V _{DC}	± 1.0 V
Power Consumption	≤3 W	
Operating Temperature	-20 °C to +55 °C	
Storage Temperature	-40 °C to +85 °C	
Operating Relative Humidity	5 % to 95 %	
Dimensions (L×W×H)	60 mm × 95 mm × 23 mm	

1.4 System Connection

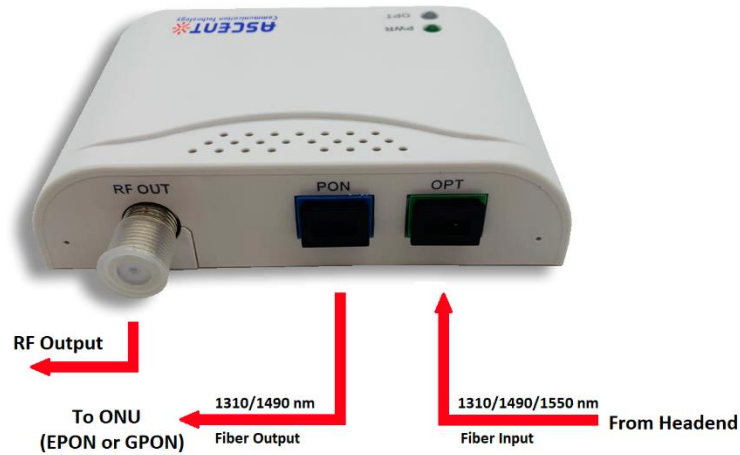

AON120D Ports

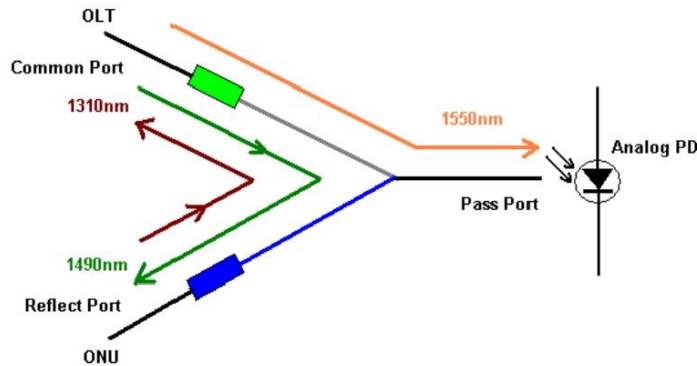

AON120D PON Signal Bypassing Diagram

1.5 Models and Options

AON120D Series FTTH Mini Node Ordering Information						
AON120D-	X-	X-	XX-	XX-	XX-	X
	RF Bandwidth		Output Power		Power Adaptor	
A	1002 MHz		AG 76dBuV @-8~2dBm		00 None (RF Powering)	
B	1218 MHz		MG 82dBuV @-2dBm		01 Australia	
	WDM		Optical Connector		02 China	
0	No WDM Filter (1550/1310/1490 all pass)		AS SC/APC		03 Continental Europe	
F	WDM Filter (1550 pass) w/o PON Port		LA LC/APC		04 North America	
W	WDM (1550 pass) w PON Port (1310/1490)		US SC/UPC		Customization	
					0 Default Standard Model	
					T DVB-T Application	

1.6 Block Diagram

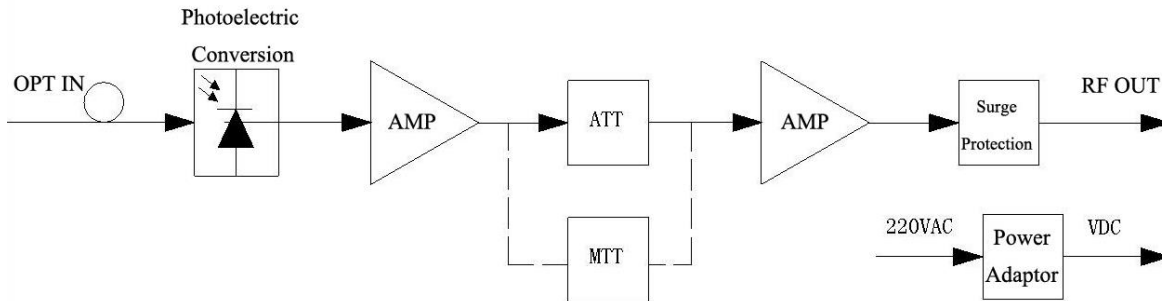

2 Configuration and Installation

This chapter introduces AON120D setup and installation. Before installing the equipment, please read this chapter thoroughly.

2.1 Equipment Inventory

On receiving your new AON120D unit, you should carefully unpack and examine the contents for loss or damage that may have occurred during shipping. Refer to warranty registration if loss or damage has occurred. The AON120D should consist of the following:

Qty	Description
1	AON120D Mini Node
1	Optional Quick Reference Guide (Ref: Online version)
1	Universal 12 VDC power supply plug-pack

2.2 Power and Cooling Requirements

The AON120D requires an external supply of 11 V DC to 16 V DC. The maximum power consumption of the unit is 3 W. A universal 12 V DC power supply plug-pack is supplied with the unit, and is suitable for 95 V AC to 265 V AC 50/60 Hz with selectable mains pins for Australia, Continental Europe, United Kingdom and United States.

The AON120D is specified for operation between -20 °C to +50 °C. Ensure that the unit is mounted in such a way as to permit airflow around the front and sides at all times.

2.3 Setting up the AON120D



Exposure to class 1M laser radiation is possible. Access should be restricted to trained personnel only.

Warning

1. Ensure that the unit is complete with all expected equipment
2. If you are mounting the unit in a wiring closet or meter box, do this **before** connecting the optical and coaxial cables. Keep in mind appropriate clearances for these cables, air flow etc.
3. Connect the RF OUT port to the RF signal output.
4. Optical Input Port: Connect to forward fiber with SC/APC connector
5. PON Pass Port: Connect to PON signal fiber with SC/APC connector.
6. Connect CATV+PON and PON Pass to the CATV Coaxial network and the ONU.
7. Connect power to the unit via the power port
8. Check that the Status LEDs is on. When optical receiving power is higher than - 12 dBm, the LED indicator will be green. When optical receiving power is lower than - 12 dBm, the LED indicator will be red.
9. Ensure that the Status Alarm LED is green. Orange or Red indicates that the received optical level is too low or too high, and is at risk of damaging the unit.
10. User can adjust the RF Output power by the adjustable attenuator: Output level adjustment range of 0 to 20 dB.

3 Distortion Performance

PIN (DBM)	VO (DBμV)	MER	BER		PIN (DBM)	VO (DBμV)	MER	BER	
			POST	PER				POST	PER
+2.0	70.9	38.8	<1.0E-9	<1.0E-9	-8.0	81.6	38.7	<1.0E-9	<1.0E-9
+1.0	82.1	38.8	<1.0E-9	<1.0E-9	-9.0	80.0	38.6	<1.0E-9	<1.0E-9
0.0	80.8	38.8	<1.0E-9	<1.0E-9	-10.0	78.3	38.5	<1.0E-9	<1.0E-9
-1.0	81.7	38.8	<1.0E-9	<1.0E-9	-11.0	76.0	38.4	<1.0E-9	<1.0E-9
-2.0	81.7	38.8	<1.0E-9	<1.0E-9	-12.0	74.3	38.2	<1.0E-9	<1.0E-9
-3.0	81.9	38.8	<1.0E-9	<1.0E-9	-13.0	72.5	37.8	<1.0E-9	<1.0E-9
-4.0	81.8	38.8	<1.0E-9	<1.0E-9	-14.0	70.4	37.5	<1.0E-9	<1.0E-9
-5.0	81.7	38.8	<1.0E-9	<1.0E-9	-15.0	68.6	36.9	<1.0E-9	<1.0E-9
-6.0	81.7	38.8	<1.0E-9	<1.0E-9	-16.0	66.7	36.2	<1.0E-9	<1.0E-9
-7.0	81.9	38.7	<1.0E-9	<1.0E-9	-17.0	64.9	35.2	<1.0E-9	<1.0E-9

- Notes: 1. Pin = +2.0 dBm to -20 dBm
 2. Test Signal: KAB3000 MER: 38.8 (dB), BER <1.0E-9
 3. Channel Load: 4CH QAM64
 4. Test Equipment: JDSU SDA4040D

CNR, MER Degradation Table

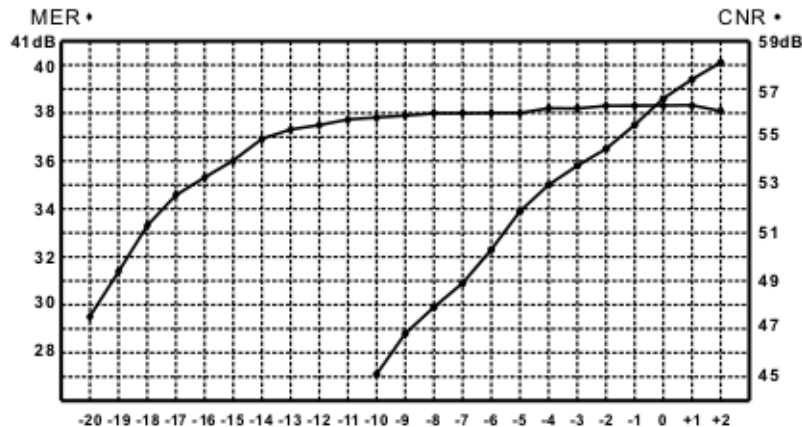

- Notes: 1. CNR test conditions: 59CH PAL-D, OMI = 3.8%
 2. Digital TV test signal: The original signal MER = 38.8 dB. BER < 1.0E-9 TV
 Input Level: 87 dbμV

4 Three-Wavelengths WDM Module

4.1 Features

- Low insertion loss
- Low return loss
- High channel separation
- High stability and reliability
- No plastic optical path

4.2 Applications

- Light circuit terminal, optical network unit
- FTTH
- Optical transceiver
- Cable TV systems
- WDM systems

4.3 WDM Specifications

Absolute Maximum Ratings (Tc = 25 °C)

Parameter	Symbol	Value
Saturation power	Ps	2.0 mW
Forward current	If	2.0 mA
Reverse voltage	Vr	15 V
Operating temperature	Top	-40 °C to +85 °C
Storage temperature	Tstg	-40 °C to +125 °C

Optical and Electrical Characteristics (Tc = 25 °C)

Parameter	Symbol	Min.	Typ.	Max.	Unit	Remarks
Pass Channel Wavelength Range	λ		1550		nm	
Reflect Channel Wavelength	λ		1310		nm	
	λ		1490		nm	
Responsibility	R	0.93			A/W	$\lambda = 1550 \text{ nm}, P_o = 0\text{DB}$
Isolation						
Pass Channel (COM-Pass)	Iso	30			dB	
Reflect Channel (COM-Reflect)	Iso	22			dB	
Polarization Dependent Loss						
Pass Channel	PDL			0.05	dB	
Reflect Channel	PDL			0.05	dB	

Directivity		50		dB
Return loss	RL	45		dB
Insertion Loss				
Pass Channel	IL		0.8	dB
Reflect Channel	IL		0.7	dB

4.4 PD Pin Assignment

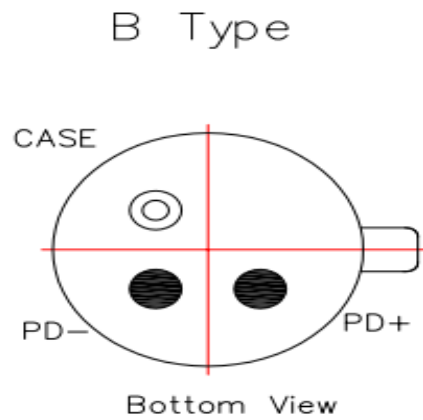

4.5 Mechanical Dimensions

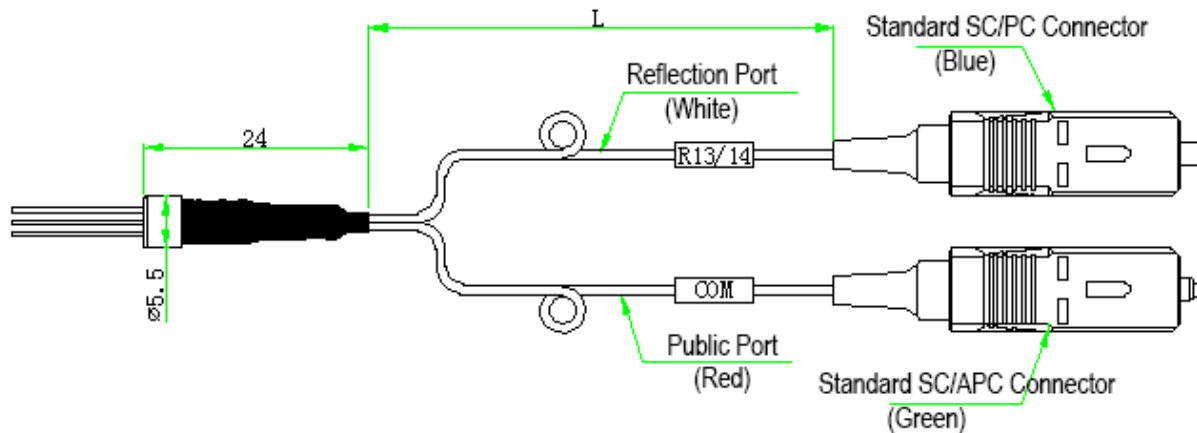

5 Troubleshooting

POWER LED off

Ensure that the unit is connected to a suitable power source. The power adapter for this equipment has an input of 220 V and an output of 12 V DC. If the STATUS LED is still off, the unit is likely to be faulty and should be returned to Ascent Communication Technology for repair.

OPT. IN LED showing red

The optical level entering the unit is too low or too high and must be adjusted externally to the unit, for optimal performance.

If the optical level entering the unit is too high, it could cause permanent damage to the unit. The signal should be disconnected and attenuated to an appropriate level, before reconnection to the AON120D. If the unit does not function as specified it is possible that the unit has been damaged and should be returned to Ascent Communication Technology for repair.

No RF output

Ensure that a forward-path signal is present on the system, at the correct wavelength for the AON120D to receive. If the signal is present, but not at the desired level, adjust the RF ATT control.

Keep the optical connector clean, a poor link will reduce the RF output level.



GERMANY

Langwiesenweg 64-71
75323 Bad Wildbad, GERMANY
Phone: +49 (0) 7081 / 17 02 0

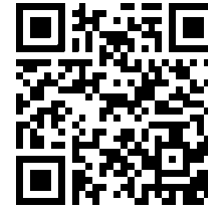

WEB: www.polytron.de



Ascent Communication Technology Ltd



AUSTRALIA

961 Mountain Highway, Boronia
Victoria 3155, AUSTRALIA
Phone: +61-488 293 682

HONG KONG SAR

Unit 9, 12th Floor, Wing Tuck Commercial Centre
177 Wing Lok Street, Sheung Wan, HONG KONG
Phone: +852-2851 4722

CHINA

Unit 1907, 600 Luban Road
200023, Shanghai CHINA
Phone: +86-21-60232616

USA

2710 Thomes Ave, Cheyenne
WY 82001, USA
Phone: +1-203 816 5188

WEB: www.ascentcomtec.com

EMAIL: sales@ascentcomtec.com

Specifications and product availability are subject to change without notice.
Copyright © 2020 Ascent Communication Technology Limited. All rights reserved.
Ver. ACT_AON120D_Mini_Node_QRG_V1c_Feb_2020